











120102EZ INSTRUCTIONAL MANUAL



120102EZ List of Components

Description	Qty	Part #	
Base only, for 4-bar stand	1	159950-B4	
Stabilizer Bar only, for 4-Bar stand	1	159950-C4	
Rod 24" Long Stainless Steel	5	159950-24	
Rod 12" Long Stainless Steel	2	159950-12	
Double Ring Clamp for reservoir	1	120141-2	
Ring Clamp (Bubble traps)	1	120149-RC	
Ring Clamp (Oxygenating Chamber)	1	159953-10	
Ring Clamp (Hi-Tech Heart Chamber)	1	159953-MEM	
Universal Stand Clamp	6	159952	

120102EZ List of Components cont.

Water-Jacketed Reservoir 2L

1

120142-2



Oxygenating Bubbler W/Inlet F/2L

1

140143-2

High-Tech Heart Chamber (Including Cannulas
#140153-OST and 140154-OST)

1

140150



Bubble Trap

1

130149



Oxygenating Chamber

1

120144EZ



120102EZ List of Components cont.

24MM Heart Adapter

1 140147



In-Line Inject Port

2ea 120151EA



Q.D. "Y" Adapters

2ea 120162



T.N.V. Y-Adapter

1 120168



Reservoir Filling Funnel

1 120140A



120102EZ List of Components cont.

Radnoti Tubing Adapter Kit	1	120140B
Heater/Bath Circulator Pump	1	170051A
Peristaltic Pump	1	170100A
Easy-Load Pump Heads	2	170110
120102 Manual	1	120102-MAN
Power Point CD	1	SystemPPCD
Water-Jacketed FlexTube Assembly		
36"	1	130159-36
72"	1	130155-72
Water Jacket Tubing		
10"	4	120159-10
20"	2	120159-20
36"	1	120159-36
40"	1	120159-40
72"	1	120159-72
Perfusate Tubing		
30"	1	120157-30
40"	1	120157-40
50"	2	120157-50
72"	1	120157-72
Gas Tubing		
20"	1	120157-20
36"	1	120157-36
72"	1	120157-72
Silicone Tubing		
20"	1	130144-188-20
72"	1	130144-188-72
Spare Tubing Kit		
120159 (Water Jacket Tubing) 10'	1	120159
120157 (Perfusate and Gas Tubing) 10'	1	120157
130144-188 (Silicone Tubing) 5'	1	130144-188

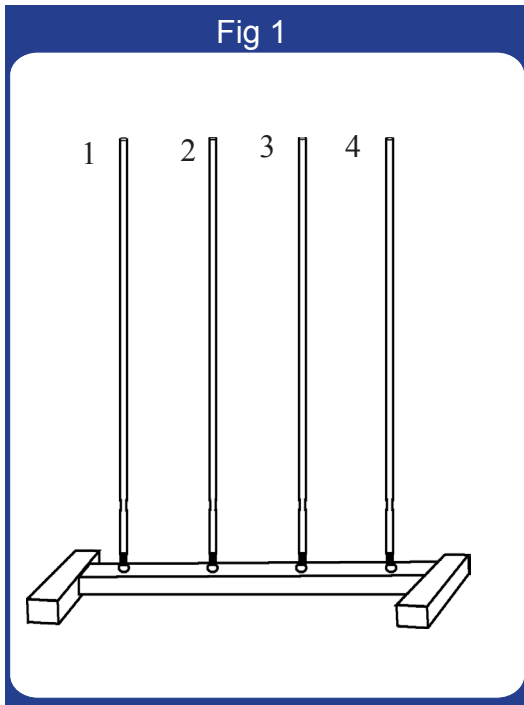

Screw 24" rods tightly into the Base.

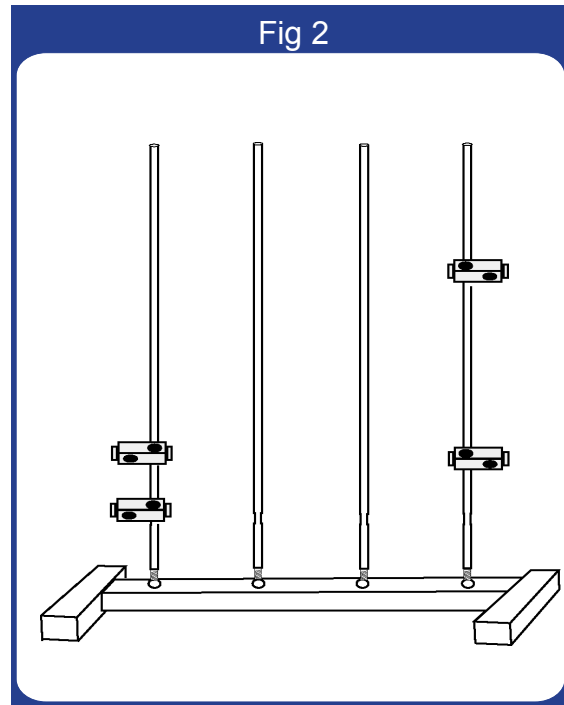

Slide 2 Universal Stand Clamps onto the rod all the way to the left. Then slide 2 Universal Stand Clamps onto the rod all the way to the right.

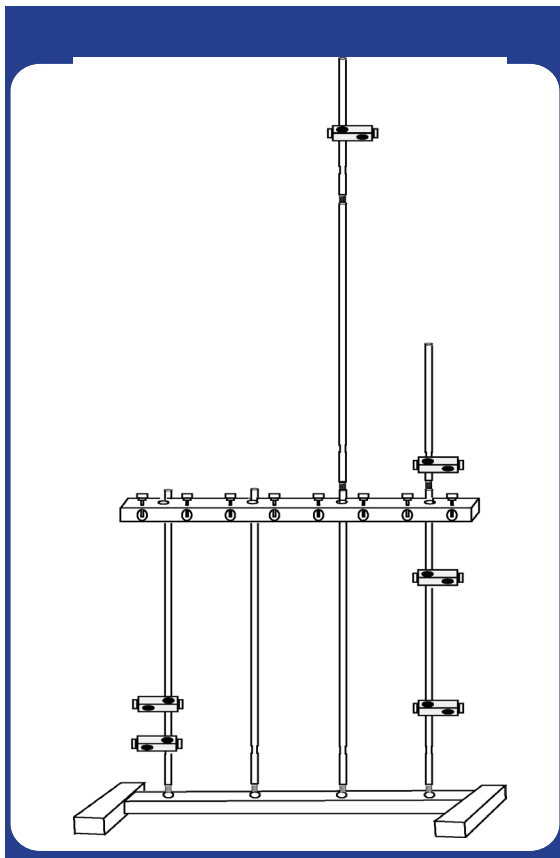

Slide the Stabilizer bar over the 4 rods and tighten near the top. Then screw a 24" rod on top of rod #3 and a 12" rod on top of that. Now screw a 12" rod on top of rod #4. Slide a Universal Stand Clamp onto rod #3 and another on rod #4.

Warning: *When placing the glass components on ring clamps, please be careful not to over tighten.*

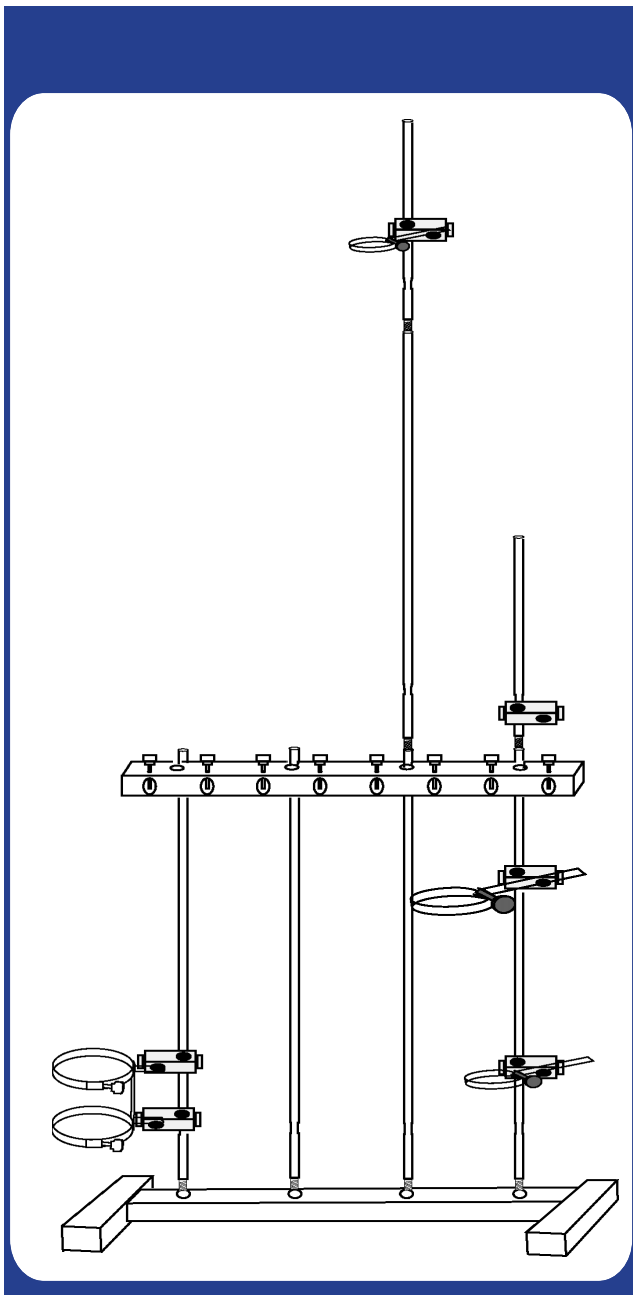

Insert Double Ring Clamp into the Universal Stand Clamp on rod #1. Insert Ring Clamp for Bubble Trap into Universal Stand Clamp on top of rod #3. Then insert Ring Clamp for Oxy Chamber into the Universal Stand Clamp at the bottom of rod #4. Now insert Ring Clamp for Heart Chamber into the Universal Stand Clamp above clamp on rod #4.

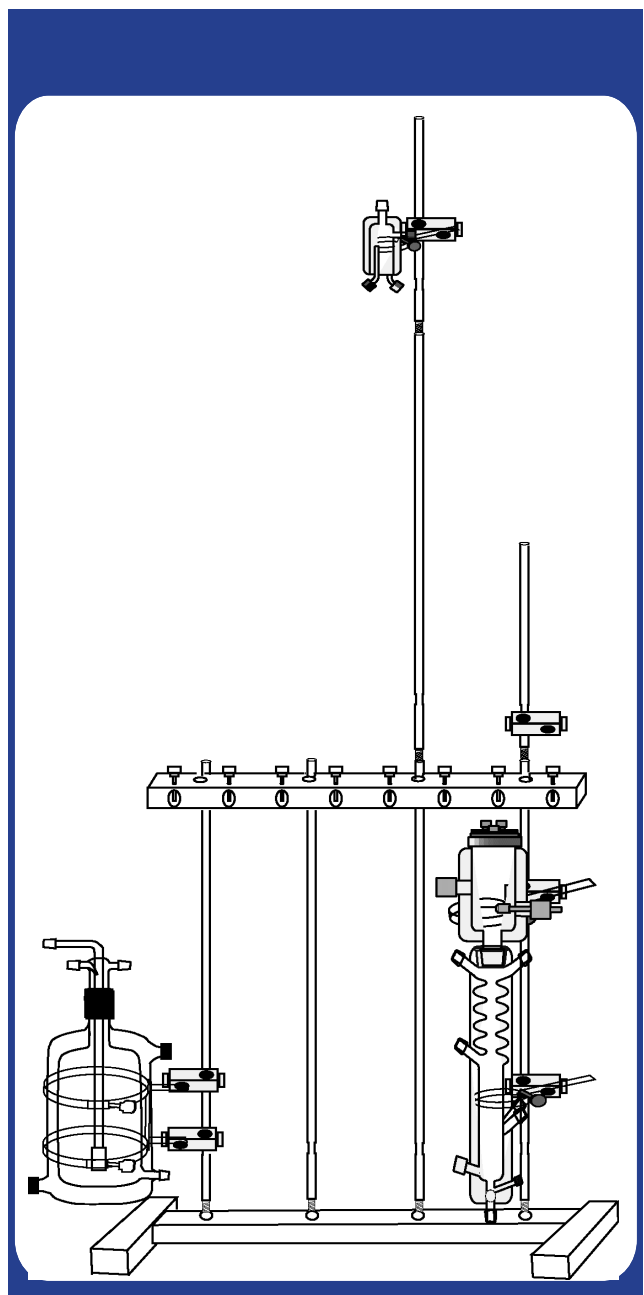
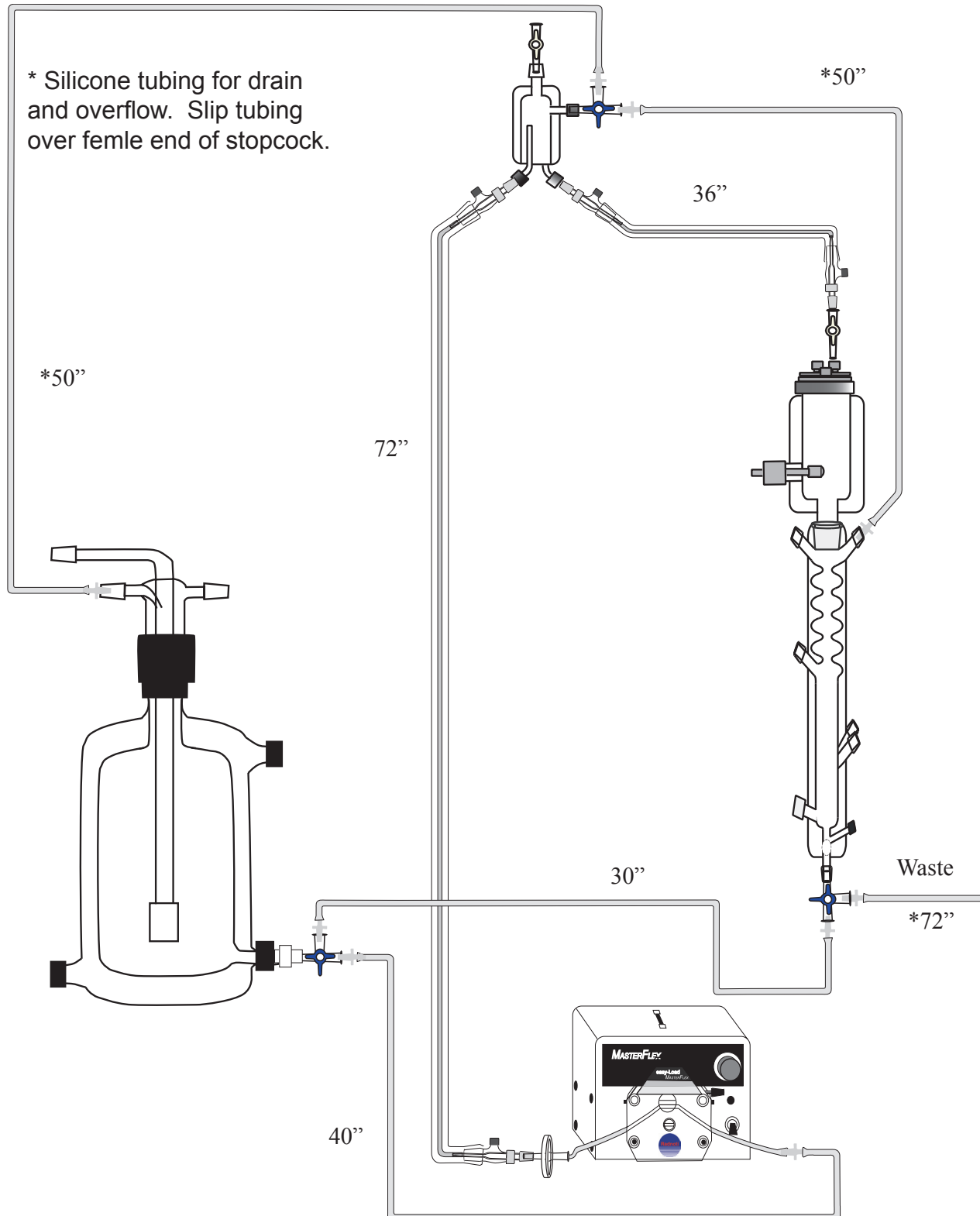
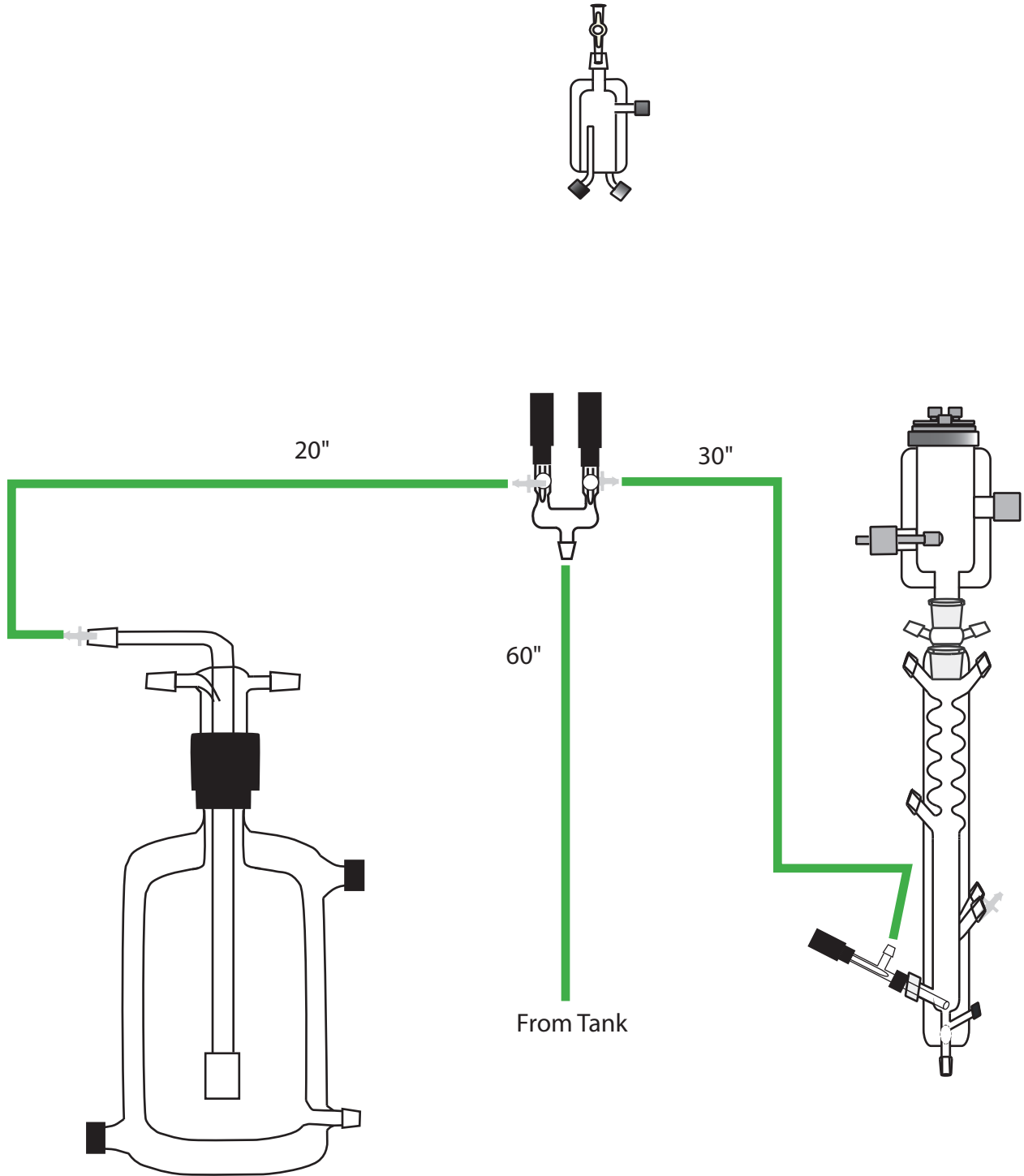

Fig 5: Place 2L Reservoir into Double Ring Clamp on rod #1. Next place Bubble Trap into Ring Clamp on top of rod #3. Now place High Tech Heart Chamber, Med into Ring Clamp. Insert rod from the lid into Universal Stand Clamp, above stabilizer bar on rod #4. Now place Oxygenating Chamber into Ring Clamp on rod #4. Make sure ground lure on the bottom of the Heart Chamber is inserted into to top of the Oxygenating Chamber.

PERFUSATE CONNECTION CHART



OXYGEN CONNECTION CHART



WATER-JACKET TUBING KIT CONNECTION CHART

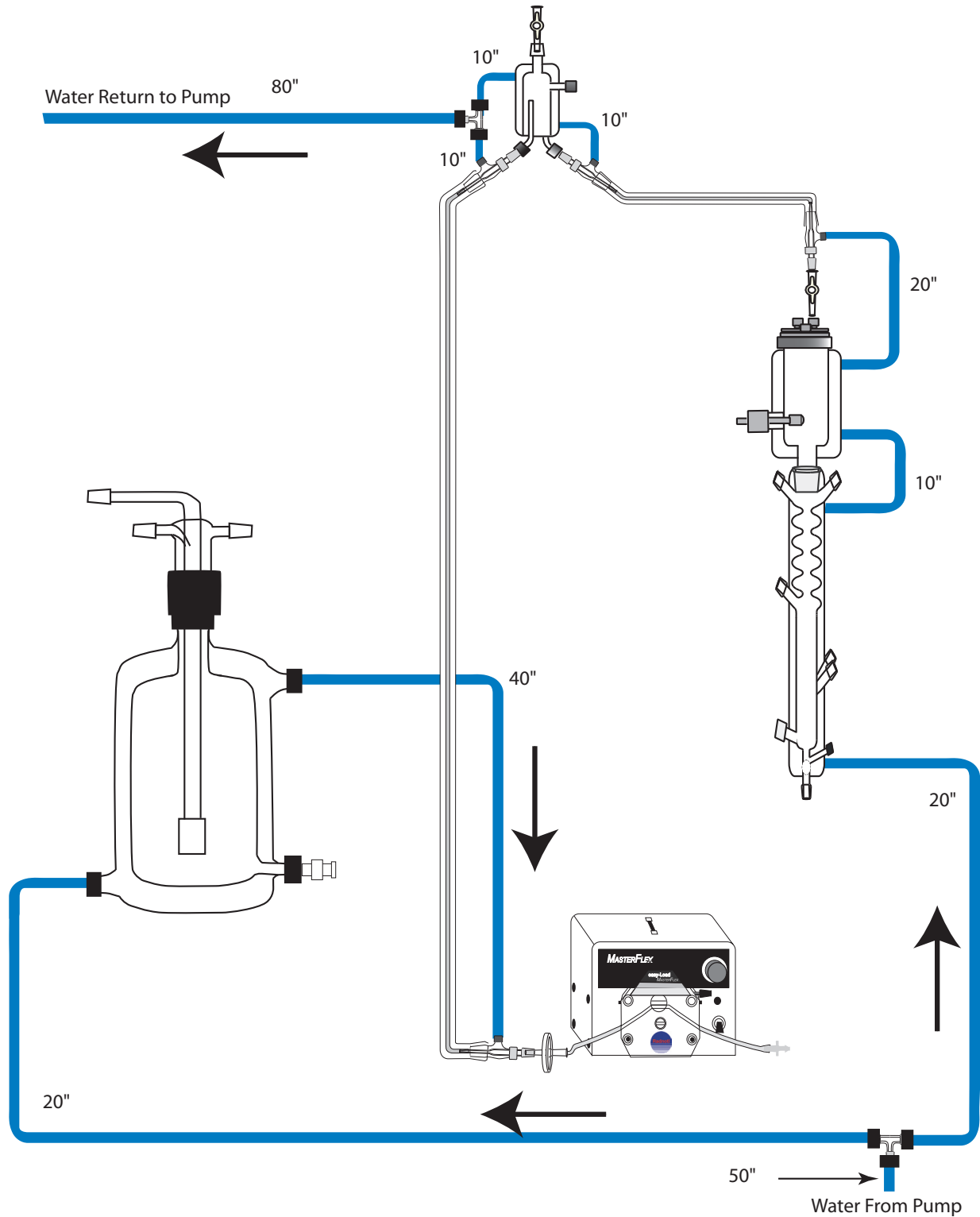



RADNOTI "QUICK DISCONNECT INSTRUCTIONS"

- A. Slide CAP-WITH HOLE onto the water line (Tygon tubing 120159).
- B. Push the Plastic Sleeve Insert into the end of the Tygon tubing with the flared end first. (Catalog No. 120160).
- C. Be sure to use 5/16 x 3/16 inch Tygon tubing (Catalog No.120159).
- D. Moisten tip of Tygon tubing before insertion into the threaded glass.
CAUTION: To Avoid Breakage, Do Not Over-Tighten The Screw Cap.

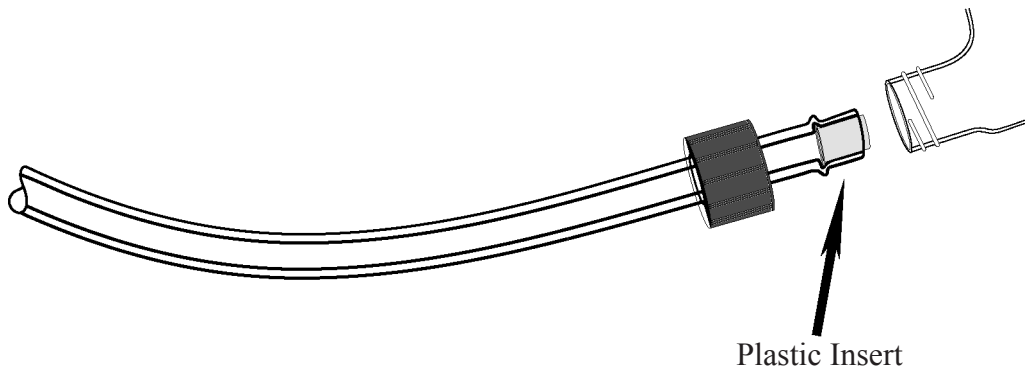

Replacement Part List:

<u>Catalog No.</u>	<u>Description</u>
120160	Plastic Sleeve Insert, 25/Pkg
120159	Tygon Tubing 5/16 x 3/16 ID, 50 Ft/Min.
160196	Drilled Cap for W/J Q.D.

RADNOTI ISOLATED PERFUSED HEART

The isolated perfused heart system, as originated by Oscar Langendorff more than a century ago, has become a mainstay of pharmacological and physiological research. The system allows the examination of cardiac inotropic, chronotropic and vascular effects without the complications of an intact animal model. The original design has evolved to encompass both constant pressure and constant flow models in both recirculating and non-recirculating modes, as well as "working heart" models 2 and 3. The Radnoti Model 1 perfused heart system has the capacity to function in any of these configurations, allowing the researcher to have maximal flexibility in experimental design. This capability is enhanced through the use of solid state monitoring and recording technology combined with precision fabrication resulting in a convenient, easy to use and easy to maintain package.

Basic Principles

During a normal cardiac contraction in a mammalian heart, the blood stored in the left ventricle is ejected at a pressure of about 80-100mm Hg into the aorta. At the base of the aorta is an ostium (hole) which feeds blood under this pressure into the coronary arteries. Langendorff maintained the isolated heart through the use of a reservoir with a pressure head that was connected via a tube to the aortic cannula. When the reservoir was opened, the perfusate was forced through the ostia into the coronary bed. This is often termed as a retrograde perfusion, in the sense that the perfusate flows down into the aorta rather than out the left ventricle through the aorta, as blood does in situ. This system, and the constant flow system which uses a pump to maintain a preset flow of perfusate into the aortic cannula, does not normally permit the heart to generate pressure-volume work. A modern modification which permits the heart to both pump fluid and utilize the normal left ventricular circulatory pathway is the "working" heart model developed by Neely et al.2, 3, in which the perfusate enters the cannulated left atria, passes through to the left ventricle and is ejected out of the aorta.

Selection of the Donor Heart

To achieve the optimum use of the perfused heart system, it is imperative that the experimenter give careful thought to the design of the experiment, the donor heart, its maintenance and instrumentation. The selection of the heart is often based on the typical or unique response of the donor organ to pharmacological or physiological stimuli or on selected metabolic or biochemical events. The most common donors are rats, rabbits, guinea pigs, ferrets, hamsters, frogs and goldfish. Note that in the latter two species there are no defined coronary vessels, merely a porous ventricle and atria. Any of these donor hearts may be accommodated in the Radnoti apparatus by the selection of appropriate cannulae.

Selection of Perfusion Solution

Once the donor heart is selected, the experimenter must then choose a media to maintain the heart. All media will have to be aerated, as the oxygen consumption of most mammalian hearts is considerable. Oxygen tension is normally kept about 550-600mm Hg at sea level to permit effective delivery to cardiac tissues, since the solubility of oxygen in saline solutions is much lower than that of blood. These elevated oxygen tensions are not needed when whole blood, washed erythrocytes, hemoglobin or fluorinated hydrocarbons are used in the media. It is possible to use a donor animal as a source and oxygenator of whole blood. The standard Radnoti system is designed primarily for the use of saline solutions without cellular or proteinaceous components. The optional membrane oxygenator can maintain adequate oxygen levels using erythrocytes but a conventional peristaltic pump may damage them as they circulate.

If a system other than whole blood is used, the media must be buffered, either with the traditional carbonate buffers such as Krebs-Henseleit, Locke's or Tyrode's or with variations of these formulas using HEPES or MES buffers. Due to the reduced viscosity of blood-free media, the flow rates are nearly twice as large as with whole blood. A substrate such as glucose (normally 5-10mM) is necessary and, dependent on experimental designs, other substrates can be utilized, such as pyruvate, lactate, fatty acids, amino acids, etc. The ionic components of the media are important and vary with the species; potassium and calcium are the most variable and critical of the ions. Due to plasma protein binding usually half or more of the total calcium in blood is bound, which is the reason for using calcium levels of 1-1.5mM in perfusate compared to serum values of 2-2.5mM. It should be noted that calcium phosphate or calcium carbonate microcrystals may form in the buffer prior to use. Finally, a plasma expander such as dextran, polyvinylpyrrolidone (PVP) or albumin may be used to maintain oncotic pressure (normally about 8-25mM Hg). Without this adjustment, edema is significant. Temperature may be maintained from 4½C for cryogenic studies to 37½C or above for heat shock studies. The cardiac electrical, contractile and metabolic activity and stability of the preparation are dependent on the temperature selected.

Heart Preparation

The constant flow system requires the use of a pump to perfuse the heart at a rate set by the experimenter. Once the flow is constant, syringe pumps can be used to conveniently titrate the heart with drugs or other agents. Changes in coronary vessel diameter are manifested as a change in perfusion pressure. This type of system is often used when the experimenter wishes to limit the substrate or oxygen available to the heart as in experimental global or partial ischemia. The coronary vessels can dilate or constrict, i.e. auto-regulate, but the total supply of oxygen and substrate is controlled by the flow rate. In the constant pressure system, the pressure head is kept constant by adjusting the reservoir level or through the use of a pump and overflow system. Changes in flow are measured volumetrically, or with fraction collectors, electromagnetic flow probes, drop counters, etc. In the constant pressure system, changes in vascular resistance can increase or decrease the supply of oxygen and substrate supplied to the heart. In the working heart system, both the aorta and the left atrium are cannulated and the atrial pressure (preload) and aortic resistance (after load) are regulated experimentally as the heart pumps liquid.

The experimenter may choose to have a non-recirculating (single pass) system or a recirculating system. A single pass system is useful when the ex

perimeter wishes to apply several agents in sequence and then allow their effects to dissipate as the agent is washed out of the heart. This approach is also useful when measuring the uptake or release of various drugs, neurotransmitters or metabolites. A recirculating system is useful when it is necessary to reduce the total volume of perfusate when utilizing expensive drugs or substrates. If recirculation continues for 15-30 minutes or more, denatured protein released from the heart will accumulate in the perfusate². The Radnoti perfused heart system has removable filters placed in the circuit to remove this denatured protein before it clogs the cardiac vessels and capillaries.

Cardiac Pacing

The experimenter must decide on whether the heart will be paced or allowed to beat spontaneously. Pacing is used to maintain a standard contractile response and metabolic demand, while spontaneous beating may permit the experimenter to measure changes in heart rate and rhythm that will occur with various drugs or manipulations. To pace a heart, the stimulus rate must exceed the natural cardiac pacemaker rate. Often the sinoatrial node is crushed or the right atrium excised to eliminate the contribution of the primary intrinsic pacemaker. Pacing voltage is determined as a set percentage (normally 110-150%) above the voltage required to capture (pace) the heart and should not have to exceed 3-5 v, with a duration of 0.1-1 msec. Hearts may be paced using plunge electrodes inserted into the cardiac tissue by running Teflon-coated wires into needles, exposing the tips of the wires and bending the wires over the tips of the needles. The needles are then pushed into the heart and withdrawn, leaving the wire embedded in the tissue. Another technique is to attach a single electrode and use a stainless steel aortic cannula as a ground. The wire can be a fine gauge Teflon coated stainless steel or platinum (obtainable at A-M systems, P.O. Box 850, Carlsborg, WA 98324). Various other electrodes have been used, such as suction, wick and sewn-on contacts. Pacing may also be used to induce arrhythmias in attempts to measure changes in fibrillation threshold.

Measurement of Contractile Force

The simplest measurement of contractile force is made using a force transducer tied to the apex of the heart with a pulley in between the heart and the transducer. In this system a measurable amount of force is lost in a rotational motion as the heart contracts, which can be compensated with a three-point mount⁶. Strain gauges may be sewn on the heart. A saline-filled balloon catheter inserted into the left ventricle is often used to measure isovolumetric work⁷. Balloons should be slightly larger than the maximum expanded volume of the ventricle to avoid effects of measuring the resistance of the balloon to stretch. Balloons may be made of plastic wrap, condoms or latex cast on models formed from the ventricle. The balloon is secured to a plastic or stainless steel tube that is connected to a pressure transducer. The balloon may be inserted by passage through the left atrium or by passing the catheter through the wall of the left ventricle for pressure measurements. In this case, a one-way valve must be placed in the aortic cannula if the intraventricular pressure exceeds the perfusion pressure. In the working heart model, contractile function can be assessed by the initial ejection pressure at the aorta and the concomitant ability to pump against an after load as adjusted via the compliance chamber and/or reach a set ejection pressure with a preload set by adjusting the height of the atrial reservoir. Pressure-volume work is determined by the total volume of fluid ejected by the ventricle over time. In any of these cases, the experimenter should determine the appropriate amount of resting force or pressure required to maintain the heart on the ascending limb of the Starling curve and avoid overstretching the heart muscle.

Other useful functions derived from contractile measurements include the first derivative, dP/dt , a determinant of the rate of change of developed pressure and the integral of pressure as an index of work. Heart rate can be monitored from force measurements or monitored independently with an ECG amplifier.

Other Experimental Options

There are a great number of physiological parameters that can be measured in the perfused heart preparation. Electro Cardiograms (ECG) are readily obtained using surface electrodes of monopolar or bipolar construction and are of interest in studies involving arrhythmias. Microelectrodes implanted in the surface myocytes can also be used for electrical measurements. Oxygen consumption can be determined with dual oxygen electrodes, one placed in the perfusate stream entering the heart, the other monitoring the effluent leaving the coronary sinus⁸. This effluent can be removed through the use of a peristaltic pump and then transferred to the second oxygen electrode. Similarly, ion selective electrodes can be placed in the effluent or perfusate stream or oxygenation chamber of the Radnoti perfused heart apparatus, permitting measurement of pH and other cations and anions. Radiolabelled compounds can be used for metabolic studies, the release or uptake of various ions or substrates. Optical studies have been performed on the fluorescence of endogenous⁹ or exogenous fluorescent compounds.

Anesthesia and Cardiac Removal

1. Preparation of the Donor

The anesthetic(s) used will depend on the donor, potential problems with side effects in the experimental protocol, the extent of the surgical procedures and the regulations of your Animal Care and Use committee. The most common are barbiturates, such as nembutal or thiopental, ethyl ether and common volatile surgical anesthetics, the latter two which can present potential personnel hazards due to fire or intoxication. Due to the danger of an overdose of the anesthetic causing severe or prolonged cardiac impairment or hypoxia, carbon dioxide or euthanasia solutions should not be used. Unless there is an overriding experimental concern, the donor should be heparinized prior to surgery to reduce the formation of emboli in the vasculature.

2. Removal of the Heart

After achieving a surgical plane of anesthesia, the donor should be placed in a dissecting tray near the isolated heart apparatus. The experimenter will

be able to function most efficiently if extra sets of sutures and instruments are positioned close at hand. Cardiac removal may be performed as a surgical procedure by intubating the donor, putting an extension tube on the aortic cannula to permit it to be inserted into the donor. After exposing the heart by a sternotomy and cutting and retracting the rib cage, the two loose ties are placed around the aorta. One tie is used to manipulate the aorta and the other to secure the aorta to the cannula. A slow stream of perfusate is permitted to flow through the aortic cannula, removing any air bubbles. The vena cava is then clamped above the diaphragm and the heart flooded with ice cold perfusate to arrest its motion. The pulmonary artery is then incised, followed by an incision across the aorta. The cannula is then inserted and secured. The tip of the aortic cannula should not be inserted below the base of the aorta, as the ostium will be occluded and perfusion restricted. Once perfusion has commenced, the heart may be removed and the cannula disconnected from the extension tube and placed in the apparatus.

Cardiac removal may also be performed by a simple medical incision (median sternotomy) with the blunt end of a pair of blunt-sharp pointed scissors to open the thoracic cavity. This is followed by exposure of the heart, opening of the pericardium, support of the organ and removal of the heart by cutting across the arch of the aorta and the vena cava. Care should be taken that the aorta not be cut so short as to impair mounting on the cannula. The heart may be placed in a beaker of chilled, heparinized perfusate to arrest the beating of the heart and the organ then mounted on the aortic cannula as perfusate is flowing from the cannula. Some researchers prefer to use two pairs of tweezers to position the aorta onto the cannula, but care must be taken to avoid puncturing the aorta. The heart can be held on the cannula with a blood vessel clamp such as Dieffenbach serafine, while tying the heart onto the aortic cannula with sutures. The most critical part of the preparation is the delay in time from the removal of perfusion in the donor to the reperfusion of the heart, since this normally highly metabolically active organ has only the oxygen and substrate contained in the vessels at the time of removal to sustain itself.

Perfusion of the Heart

Once mounted on the cannula, the heart should begin to beat strongly within seconds of reperfusion. The pressure of the perfusate, if a constant flow system is used, should be carefully monitored to avoid under perfusion or over perfusion. Perfusion rates are about 3-15ml/g heart weight for constant flow systems using Tyrode's, etc., and for both constant pressure and constant flow systems the initial pressure should be about 50-60mm Hg for most mammalian hearts, dependent on the donor, heart rate (pacing), oxygen delivery and work output. Physiologically normal perfusion pressures of 80-100mm Hg as in blood-perfused hearts are not used in saline-perfused hearts due to enhanced edema and potential valve damage. The heart will stabilize rapidly and most experiments can begin within 10-15 minutes after the preparation has been mounted and the various monitoring systems attached. The heart should be functional for several hours, although it is prudent to reduce the experimental time as much as possible. Preparations will suffer edema if uncompensated by a plasma expander concomitant with protein loss from the heart.

If a working heart preparation is utilized, the left atrium must be cannulated after the heart is being perfused through the aorta. The security of the cannula is tested by the opening of the atrial reservoir prior to switching from aortic perfusion. Once secured, the atrial pressure head is adjusted (normally 2-5mm Hg) and then the perfusate switched from the aorta to the atria. Aortic pressure development can be monitored via a pressure transducer inserted to a T-connection from the aortic cannula. The aortic compliance is adjusted by adjusting the amount of air in the compliance chamber. After load is also adjusted by the height of the outflow of the aortic cannula (60-70mm Hg).

Post Experimental Cleanup

After the experiment has been completed, the experimenter should take care to scrupulously clean the equipment. Most of the Radnoti apparatus is borosilicate glass, which can be cleaned with a wide range of soaps, dilute HCl or HNO₃ or other solvents. Chromic acid is not recommended due to possible heavy metal contamination of the system. The non-glass portions should be treated with aqueous soap solutions. The equipment should have a final extensive rinse in distilled water. Areas to be especially well cleaned are aerator, tubing, syringe ports, cannula, pressure transducer fittings as well as balloon catheters and electrodes inserted in the heart. The tubing should be inspected at the pump head for wear. For more details on cleanup, see page 30 of the Radnoti Glass Catalog

Troubleshooting

The isolated heart preparation is normally very stable and reproducible once the experimenter has gained familiarity with it. If there is a rapid deterioration that unexpectedly occurs in two preparations consecutively, this is a strong indication of a problem. Many times this failure is due to the growth of bacteria and the release of endotoxins into the perfusate. Initial corrective measures should include: 1. A thorough cleaning of the apparatus and replacement of tubing, 2. Replacement of solutions (which have a limited storage life in the refrigerator), 3. A check of the water source, 4. A check of aeration, the appropriate gas mixture and pH of the aerated buffer at the normal operating temperature. Records should be kept of new purchases of substrate and salts. Certain toxic agents used by experimenters may be difficult to clean from the system and may require the use of organic solvents or the removal of tubing after each use as well as the use of a separate reservoir.

Tubing should be thoroughly pre-rinsed to remove plasticizers and the use of a high-quality silicone or Tygon tubing is recommended. Note that silicone tubing is extremely gas permeable; oxygen and other gas losses can be considerable. The use of high quality water is essential; some experimenters use small amounts of EDTA (0.1mM) to chelate trace heavy metals in suspect water supplies, although this is less of a problem with modern multiple cartridge ion-exchange systems.

Recommended Reading

If the experimenter is not conversant with cardiovascular pharmacology and physiology, there are a number of excellent texts that will introduce this area to you. Besides the medical physiology and pharmacology standards, there are a number of specialized texts. Pharmacologic Analysis of Drug-receptor Interaction by Terrence P. Kenakin (Raven Press, NY 1987) is a compact text with practical emphasis on isolated tissues and organs in pharmacological research. There are also a number of handbooks on isolated cardiac preparations available through Hugo-Sachs Elektronik, D-79229 March-Hugstetten, Germany,

Frank A. Lattanzio, Jr. Assistant Professor of Pharmacology, Eastern Virginia Medical School

These values are obtained from a variety of sources and are displayed to demonstrate the approximate ranges of these values. Values are for adult animals. Heart rate and blood pressure are taken at rest. Cation values are from serum. Left ventricular volume (LVV) is given for a balloon inserted into the left ventricle. CF (coronary flow) is given for a saline solution at 50-60 mmHg Animal Heart Rate

bpm Blood Pressure mm/Hg Na

mM K

mM Ca

mM Mg

mM LVV

ml CF

ml/min/

gm/heart

Cat 110-140 125/70 163 4.4 1.3 0.7 0.7-2.4 2-3

Rat 330-360 129/91 140 5.7 2.6 1.1 0.1-0.2 8-10

Guinea Pig 280-300 120/170 145 7.4 2.6 1.2 0.1-0.2 5-8

Mouse 600-655 135/106 2.1 0.7

R. pipens 37-60 31/21

Carp 40-78 43

Rabbit 205-220 110/73 155 4.6 3.5 1.6 0.4-0.7 2-5

References:

1. Langendorff, D. (1895) *Pfluegers Arch.* 61-291
2. Neely, J.r., Liebermeister, H., Battersby, E.J. and Mrgan, H.E. (1967) *Am. J. Physiol.* 213:804.
3. Neely, J.R. and Rovetto, M.J. (1973) *Methods in Enzyme.* 34:45.
4. Reichel, H. (1976) *Basic Res, Card.* 71:1.
5. Thandroyen, P.T. (1982) *J. Mol. Cell. Card.* 14:21.
6. Beckett, P.R. (1970) *J Pharm. Pharmac.* 22:818.
7. Kadas. T. and Opie, L.H. (1963) *J. Physiol.* 167:6P.
8. Fischer, R.B. and Williamson, J.R. (1961) *J. Physiol.* 158:86
9. Chance, B. Williamson, J.R., Jameison, D. and Schoener, B. (1965) *Biochem. Zeitsch.* 341:357.
10. Lattanzio, F.A. and Pressman, B.C. (1986) *BBRC* 139:816.

These procedures and devices are intended for research and are experimental. All statements, technical information and recommendations herein are based on tests and sources we believe to be reliable, but the accuracy or completeness thereof is not guaranteed.

Disclaimer

Before using, user shall determine the suitability of the product for its intended use, and user assumes all risk and liability whatsoever in connection therewith. Neither seller nor manufacturer shall be liable in tort or in contract for any loss or damage, direct, incidental, or consequential, arising out of the use or the inability to use product. No statement or recommendation not contained herein shall have any force or effect unless in an agreement signed by officers of seller and manufacturer.

Glassware Maintenance & Post Experimental Cleanup

Post Experimental Cleanup

After the experiment has been completed, the experimenter should take care to scrupulously clean the equipment. It is important to remember that the solutions that can sustain the heart and muscle will also provide excellent media for bacteria. The cleaning procedures will be dependent upon the types of chemicals and biological materials that are being used, the types of measurements that are being made and what substances can interfere with those measurements and the frequency of the use of the equipment and number of operators involved. Non-phosphate soaps are preferred, since insoluble phosphates can form from calcium and magnesium in physiological salt solutions. Note that bactericidal soaps may contain iodine or other materials which can affect isolated tissues and cells. Cleaning supplies and equipment, such as brushes, should be used only for cleaning this glassware and not used for other lab cleaning procedures. Questions and procedures noted here should be adjusted in accordance with your licensed procedures and the recommendations of your safety personnel.

Shared equipment is the most difficult to maintain properly. In order to maintain equipment properly, it is generally best (1) to assign the maintenance or the oversight of the equipment to one individual, who will monitor equipment and maintain cleaning supplies (2) to have written protocols posted with the equipment (3) to have a logbook where cleaning dates, as well as notification of problems, suggestions, etc., can be recorded.

Often overlooked as a source of contamination is the water circulator supply. This should be kept clean and the bath rinsed and solution changed to reduce precipitate build up. Covering equipment to reduce air borne contamination from microbes and spores is useful. Note that when baths are used intermittently, the lack of frequent cleaning and the lack of solutions rinsing out bacteria that are deposited in the tubing may result in a contamination problem when the system is finally used. A convenient rule of thumb for testing for contamination in preparations that you have found reliable is that two consecutive experimental failures that are not explained by an obviously damaged sample, poor surgical or dissection techniques or solution problems may be caused by bath contamination.

Glassware

Much of the Radnoti apparatus is borosilicate glass, which can be cleaned with a wide range of soaps, ethyl alcohol, dilute HCl or HNO₃ (0.1 M) or other solvents. Extensive flushing with distilled, deionized water to remove all traces of the cleaning agents and salts is recommended. Large glassware, such as reservoirs or assemblies can be flushed in place, but care must be taken to thoroughly clean aerators, stopcocks and associated parts. Aerators should be blown dry using gas or air at the final water rinse. If acid is used, the runoff water should not be more acidic than the normal water pH. As with the use of any chemicals, proper protective gear and training are essential to reduce personnel hazards and experimental and environmental contamination. Heated acid or chromic acid is generally not recommended due to personnel hazards and possible heavy metal contamination of the system.

If very lipophilic substances (prostaglandins, ionophores, certain dyes, etc.) are used, rinses with ethyl alcohol or the most appropriate organic solvent can be used first, but this will necessitate thorough cleaning afterward to remove any traces of the organic solvent.

Use of toxins, biohazard materials, and radiochemicals can present considerable complications to a generalized cleaning procedure. Having an apparatus and a contained area dedicated to these procedures reduces problems. Diluted bleach can be used on glassware, but must be rinsed extensively. The use of disposable tubing and stopcocks will assist in cleanup, as will scheduling a run of these procedures, rather than intermittent experiments, if non-dedicated equipment must be used. Glassware can be sterilized but all fixtures, such as aerators, stopcocks caps, etc., should be removed prior to sterilization.

The glass aerators can be cleaned with water, or dilute acid if clogged. The use of water or gas under high pressure can result in damage to the glassware and personnel and therefore is not recommended. After a general soap and water rinse to remove soluble materials, cleaning with 0.1M HCl or 0.1 M HNO₃ for several hours or overnight, followed by an extensive water rinse, will usually remove most contaminants. If this does not work, 1 M acid can be tried. Because the glass frit filaments are thin, high concentrations of acids, or especially alkalis, can destroy them and are not recommended.

Non-glass items

Initial cleaning of non-glass items should be with aqueous soap solutions. Depending upon the chemical resistance of the materials, the use of other solvents, cleaning procedures or sterilization may be possible. Areas and items to be especially well cleaned are the aerator, tubing, syringe ports, cannulae, pressure transducer fittings, septa, balloon, along with other catheters, and electrodes (oxygen, pacing, ion selective, etc.). Tubing should be inspected at the pump head for wear. Note that the interior of tubing can gradually be roughened during use and the abraded areas will form sites for bacterial growth. Tubing should be a high grade with low plasticizer leaching. Note that silicone tubing is very permeant to gases, so it should not be generally used to transport gassed solutions.